

Parts List

Technical Manual
8-026
Issued: 12/98
Supersedes: 9/96

Manual No. 251579
Rev. C

METER REGISTER

SERIES
7886

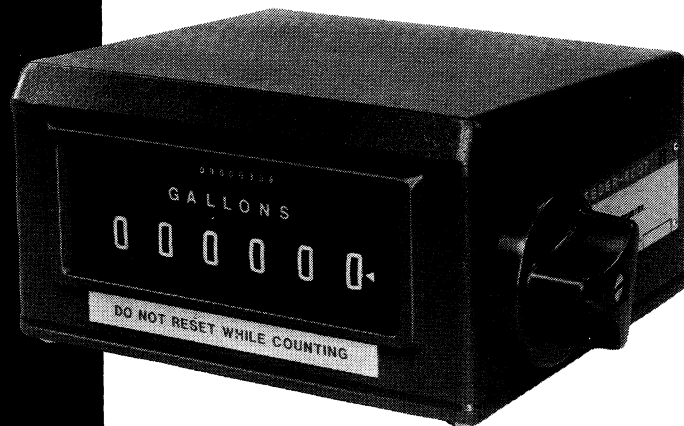

VEEDER-ROOT 

ITEM NO.	PART NO.	PART NAME	QUANTITY PER UNIT
1	80602-7-045	Cover	1
2	511810-001	Retaining Ring	19
3	74800-360	Washer (0.005)	As Req.
4	11071-208	Washer (0.010)	As Req.
4a	885005-050	Washer (0.003)	As Req.
5	11071-159	Washer (0.031)	As Req.
6	324601-001	Pinion-Transfer	4
6A	324601-002	Pinion-Transfer	1
7	324687-003	Shaft-Pinion	1
8	11071-159	Washer (0.031)	5
9	324744-001	Detent Lever Group	1
10	310300-368	Spring-Clutch	1
11	324765-001	Roller	1
12	511807-001	Retaining Ring	1
13	324651-001	Brake	1
14	510055-030	Lockwasher (No. 2)	1
15	500740-001	Screw (2-64)	1
16	511805-324	Retaining Ring	22
16a	511805-329	Retaining Ring (0.025)	As Req.
17	328825-001	Wheel Shaft Group (Also includes Item Nos. 8, 16, and/or 16a)	1
18	884010-019	Sleeve-Shutter	1
19	11017-905	Washer (0.014)	As Req.
20	11071-869	Washer (0.006)	As Req.
21	312020-872	Kit Cam-Multiple w/key	1
22	324602-001	Eccentric	6
23	324603-001	Locking Disc	6
24	324824-001	Middle and Left Wheel	5
25		Right Hand Wheel	1
	328823-001	0-9 and 10 Grads W/B	
	328823-002	0-9 and 100 Grads W/B	
26	324686-003	Shaft-Wheel	1
27	11071-965	Washer (0.040)	As Req.
28	324645-001	Shutter	1
29	324757-001	Knob	1
30	503648-001	Screw	1
31	328826-001	Reset Shaft Group (Also includes Item Nos. 3, 4, 8 & 16)	1
32	324660-002	Shaft-Reset	1
33	324597-002	Finger-Reset	6
34	310340-587	Spring	1
35	324644-001	Pawl-No Back	1
36	324655-001	Arm-Reset	1
37	511807-001	Retaining Ring	3
38	310300-329	Spring-Anti-Topping	5
39	324693-001	Shaft-Stop	1
40	328829-001	Anti-Topping Finger Shaft Group (Also includes Item Nos. 2, 3, 4, 4a, & 8)	1
41	324682-002	Shaft-Anti-Topping	1
42	324596-003	Finger-Anti-Topping	6
43	11071-208	Washer (0.010)	2
44	310300-330	Spring-Reset	1
45	324747-001	Clutch Lever Group	1
46	324743-001	Reset Lever Group	1
47	310300-331	Spring-Detent	1
48	74800-291	Washer (0.056)	As Req.
49	11071-485	Washer (0.010)	As Req.
50	11017-833	Washer (0.005)	As Req.
51	511807-001	Retaining Ring	1
52	324749-001	Left-Hand Plate Group (Also includes 59, 60, 61)	1

ITEM NO.	PART NO.	PART NAME	QUANTITY PER UNIT
53	Deleted		
54	370100-015	Screw (10-32)	2
55	510031-001	Lockwasher (No. 10) (Service Only)	2
56	403071-419	Gear-Register	1
57	510187-001	Pin, Groove	1
58***	324647-002	Bar, Rear Mounting	1
59	324748-002	Bracket Group	1
60	510057-001	Lockwasher (No. 4)	2
61	501249-001	Screw (4-40)	2
62	325043-001	Clutch Shaft Group (Also includes Item Nos. 2, 96, & 96A through 96H)	1
63	510176-001	Pin	1
64	324662-001	Bevel Gear	1
65	512900-190	Pin-Spirol	1
66	324661-001	Bevel Gear	1
67	324754-001	Right-Hand Plate Group	1
68 †	501700-137	Screw (6-32)	2
††	510500-419	Screw (6-32)	2
69	See Note ●●●	Totalizer Group	1
70	324734-001	Pointer	1
71	510500-330	Screw-Self Tapping	1
72	Deleted		
73	Deleted		
74	324756-002	Shaft-Knob	1
75	324610-001	Housing	1
76	325171-001	Name Plate	1
77	510506-001	Drive Screw	4
78	76124-005	Gasket	1
79	70718-025	Flange	1
80	Deleted		
81	510500-456	Screw	3
82	510003-006	Lockwasher	4
83	503344-032	Screw-Seal	2
84	370100-017	Lockwasher (0.250)	3
85	370100-016	Screw (1/4-28 x 3/4) (THD Forming)	3
86		Crystal	1
	328822-001	Gallons	
	328822-009	Dekaliters	
	328822-010	Barrels	
	328822-011	Liters	
	328822-012	Litres	
	328822-013	Dekalitres	
87	11853-285	Seal Wire	1
88	44602-005	Lead Seal	1
89	403071-420	Gear-Idler	1
90	511800-106	Ring-Retaining	1
91	328065-001	Label-Warning	1
92	503300-111	Screw	2
93	885005-937	Washer-Wave Spring	1
94	885005-789	Washer	As Req.
95	885005-791	Washer	As Req.
96	324600-001	Disc-Clutch	1
96A	320279-001	Spring	1
96B	320255-001	Disc	1
96C	324598-001	Coupling	1
96D	324599-001	Driver	1
96E	324663-001	Shaft-Clutch	1
96F	310325-270	Spring	1
96G	512921-001	Pin-Spirol	1
96H	11071-905	Washer (0.014)	1
97	885005-791	Washer	2

Note: Items indented under a Group are part of that Group and will be included with the Group when ordered. Individual items may be ordered as individual parts.

* After installing retaining ring (Item 16), pull wheel group against retaining ring. Manually rotate the wheel. If it does not spin freely, replace Item 16 with Item 16a.

** Use Items 3, 4 and 5 as required to obtain end play of between 0.005 and 0.012 inch.

● Use Items 49 and 50 on left side and Items 3, 4 and 5 on right side as required for proper totalizer bevel gear engagement while maintaining 0.007 inch maximum shaft end play.

●● Use Items 3, 4 and 5 as required to adjust the clutch for proper operation with the input clutch while maintaining a maximum end play of 0.007 inch.

●●● When Serial No. of Register is 323829 or higher, order 324633-006 for totalizer with right hand wheel 0-9 black on white. Order 324633-007 for totalizer with all wheels 0-9 white on black. When Serial No. of register is 323828 or lower, order 312020-902 for totalizer with right hand wheel 0-9 black on white. Order 312020-903 for totalizer with all wheels 0-9 white on black.

† For units with Serial Number below 538693.

†† For units with Serial Number 538693 and above.

*** For service orders for item No. 58 - REF Kit No. 370020-024

**GEAR PLATE ASSEMBLY
(TYPE 5)**

**GEAR LIST
(Item 103)**

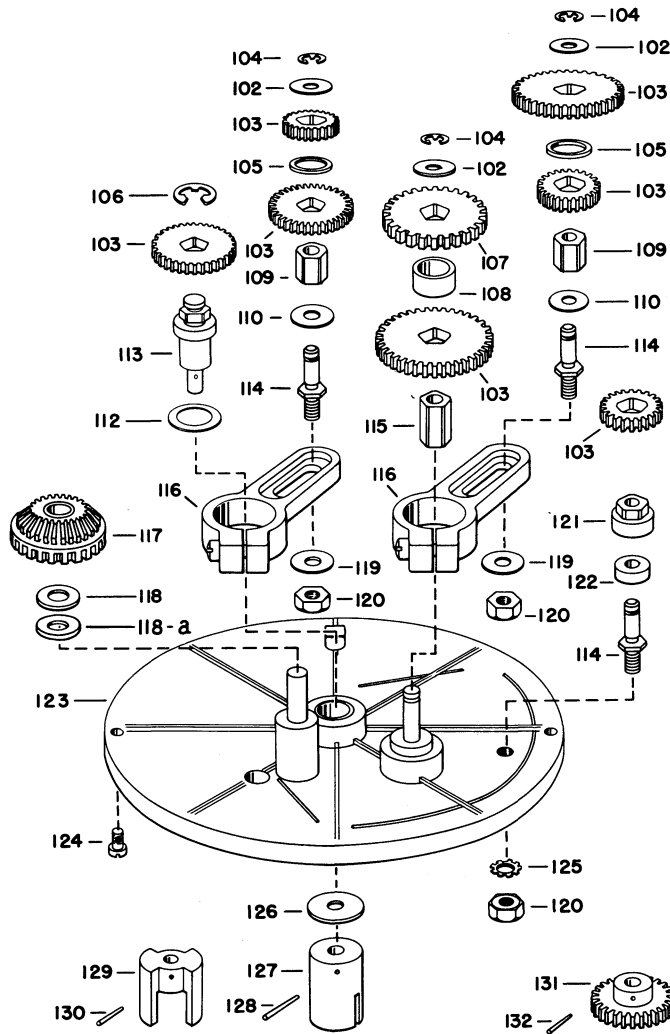

PART NO.	NO. OF TEETH	PART NAME
77348-005	19	*Gear
32996-019	19	**Gear
311427-120	20	*Gear
311427-110	20	**Gear
311427-130	26	**Gear
32996-028	28	Gear
32996-029	29	Gear
32996-030	30	Gear
32996-031	31	Gear
32996-032	32	Gear
32996-033	33	Gear
32996-034	34	Gear
32996-035	35	Gear
32996-036	36	Gear
32996-037	37	Gear
32996-038	38	Gear
32996-039	39	Gear
32996-040	40	Gear
32996-041	41	Gear
32996-042	42	Gear
32996-043	43	Gear
32996-044	44	Gear
32996-045	45	Gear
32996-046	46	Gear
32996-047	47	Gear
32996-048	48	Gear
32996-049	49	Gear
32996-050	50	Gear
32996-051	51	Gear
32996-052	52	Gear
32996-053	53	Gear
32996-054	54	Gear
32996-055	55	Gear
32996-056	56	Gear
32996-057	57	Gear
32996-058	58	Gear
32996-059	59	Gear
32996-060	60	Gear
32996-061	61	Gear
32996-062	62	Gear
32996-063	63	Gear
32996-064	64	Gear
32996-065	65	Gear
32996-066	66	Gear
32996-067	67	Gear
32996-068	68	Gear
32996-069	69	Gear
32996-070	70	Gear
32996-071	72	Gear
32996-075	75	Gear
32996-076	76	Gear
32996-080	80	Gear
32996-084	84	Gear

*Round hub/round hole
**Pentagon hub/round hole

ITEM NO.	PART NO.	PART NAME	QUANTITY PER UNIT
102	11071-135	Washer (0.010)	3
103	See Gear List.	Change Gears	
104	511807-001	Retaining Ring	3
105	11071-199	Washer (0.047)	2
106	511810-001	Retaining Ring	1
107	70827-005	Gear (25T)	1
108	14571-792	Spacer	1
109	33534-015	Bushing	2
110	11071-171	Washer (0.020)	2
112	11071-929	Washer (0.010)	1
113	70659-010	Drive Shaft	1
114	326586-001	Stud	3
115	33534-050	Bushing	1
116	33534-005	Swing Arm Assembly	2
117	70828-005	Gear Assembly	1
118	11071-479	Washer (0.030)	1

ITEM NO.	PART NO.	PART NAME	QUANTITY PER UNIT
118a	11071-333	Washer (0.020)	As Req.
	11071-325	Washer (0.010)	As Req.
	11071-803	Washer (0.005)	As Req.
119	11071-187	Washer (0.031)	2
120	511038-001	Hex Nut (10-32)	3
121	74843-005	Bushing	1
122	65009-005	Spacer	1
123	70856-010	Gear Plate	1
124	502230-001	Flat Fil. Hd. Screw (8-32 x 1/4")	2
125	510002-001	Lockwasher	1
126	11071-933	Washer (0.010)	1
127	65004-005	Coupling	1
128	510105-177	Groove Pin (1/16" x 5/8")	1
129	33775-005	Coupling	
130	510107-002	Groove Pin (1/16" x 7/16")	
131	32948-015	24T Gear	
	65116-005	36T Gear	
132	510109-001	Groove Pin for 24T Gear	
	510108-001	Groove Pin for 36T Gear	

GEAR PLATE ASSEMBLY (TYPE 7)

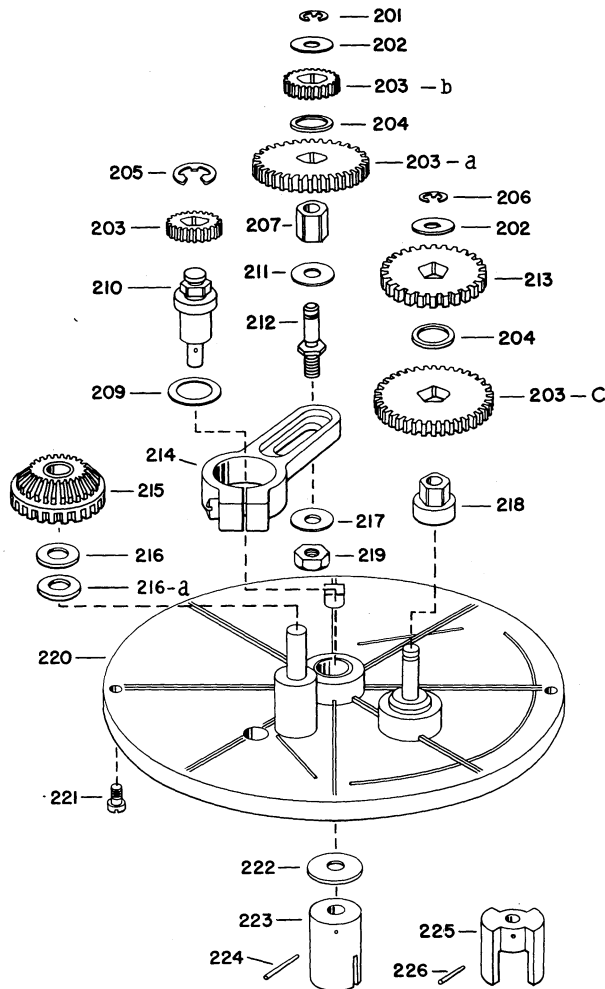

ITEM NO.	PART NO.	PART NAME	QUANTITY PER UNIT
201	511807-001	Retaining Ring	1
202	11071-135	Washer (0.010)	2
203	32996-033	33T Gear (For 4:1 ratio)	1
	32996-028	28T Gear (For 8:1 ratio)	1
203a	32996-066	66T Gear (For 4:1 ratio)	1
	32996-084	84T Gear (For 8:1 ratio)	1
203b	32996-033	33T Gear (For 4:1 ratio)	1
	32996-030	30T Gear (For 8:1 ratio)	1
203c	32996-066	66T Gear (For 4:1 ratio)	1
	32996-080	80T Gear (For 8:1 ratio)	1
204	11071-199	Washer (0.047)	2
205	511810-001	Retaining Ring	1
206	511807-001	Retaining Ring	1
207	33534-015	Bushing	1
209	11071-929	Washer (0.010)	1
210	70659-010	Drive Shaft	1
211	11071-171	Washer (0.020)	1

ITEM NO.	PART NO.	PART NAME	QUANTITY PER UNIT
212	326586-001	Stud	1
213	70827-005	Gear (25T)	1
214	33534-005	Swing Arm Assembly	1
215	70828-005	Gear Assembly	1
216	11071-479	Washer (0.030)	1
216a	11071-333	Washer (0.020)	As Req.
	11071-325	Washer (0.010)	As Req.
	11071-803	Washer (0.005)	As Req.
217	11071-187	Washer (0.031)	1
218	76551-005	Bushing	1
219	511038-001	Hex. Nut (10-32)	1
220	70856-010	Gear Plate	1
221	502230-001	Flat Fil. Hd. Screw (8-32 x 1/4")	2
222	11071-933	Washer (0.010)	1
223	65004-005	Coupling	1
224	510105-177	Groove Pin (1/16" x 5/8")	1
225	33775-005	Coupling	1
226	510107-002	Groove Pin	1

**GEAR PLATE ASSEMBLY
(TYPE 1)**

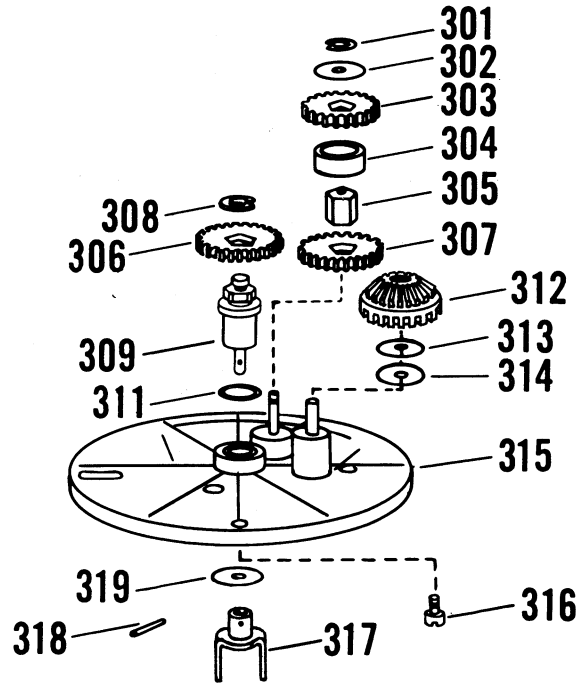

ITEM NO.	PART NO.	PART NAME	QUANTITY PER UNIT
301	511807-001	Retaining Ring	1
302	11071-135	Washer (0.010)	1
303	70827-005	Gear (25T)	1
304	14571-792	Spacer	1
305	33534-050	Bushing	1
306	73296-195	39T Gear (For 1:1 ratio)	1
	73296-130	26T Gear (For 2:1 ratio)	1
307	73296-195	39T Gear (For 1:1 ratio)	1
	73296-260	52T Gear (For 2:1 ratio)	1
308	511810-001	Retaining Gear	1
309	70659-010	Drive Shaft	1
311	11071-929	Washer (0.010)	1

ITEM NO.	PART NO.	PART NAME	QUANTITY PER UNIT
312	70828-005	Gear Assembly	1
313	11071-479	Washer (0.030)	1
314	11071-333	Washer (0.020)	As Req.
	11071-325	Washer (0.010)	As Req.
	11071-803	Washer (0.005)	As Req.
315	70856-010	Gear Plate	1
316	502230-001	Flat Fil. Hd. Screw (8-32 x 1/4")	2
317	68845-005	Coupling	1
318	510107-002	Groove Pin (1/16" x 7/16")	1
319	11071-933	Washer (0.010)	1



6th Avenue at Burns Crossing, P.O. Box 1673, Altoona, PA 16603-1673 Phone (814) 695-4476, or (800) 873-3313, Fax (814) 695-7605, or (800) 234-5350
 BRAZIL: Sao Paulo • CANADA: Mississauga, Ontario • ENGLAND: Richmond Surrey • FRANCE: Aulnay-Sous-Bois • GERMANY: Aldingen • SINGAPORE: Singapore